

SZLIFIERKA TAŚMOWA

SI-2830 30mm Belt Sander

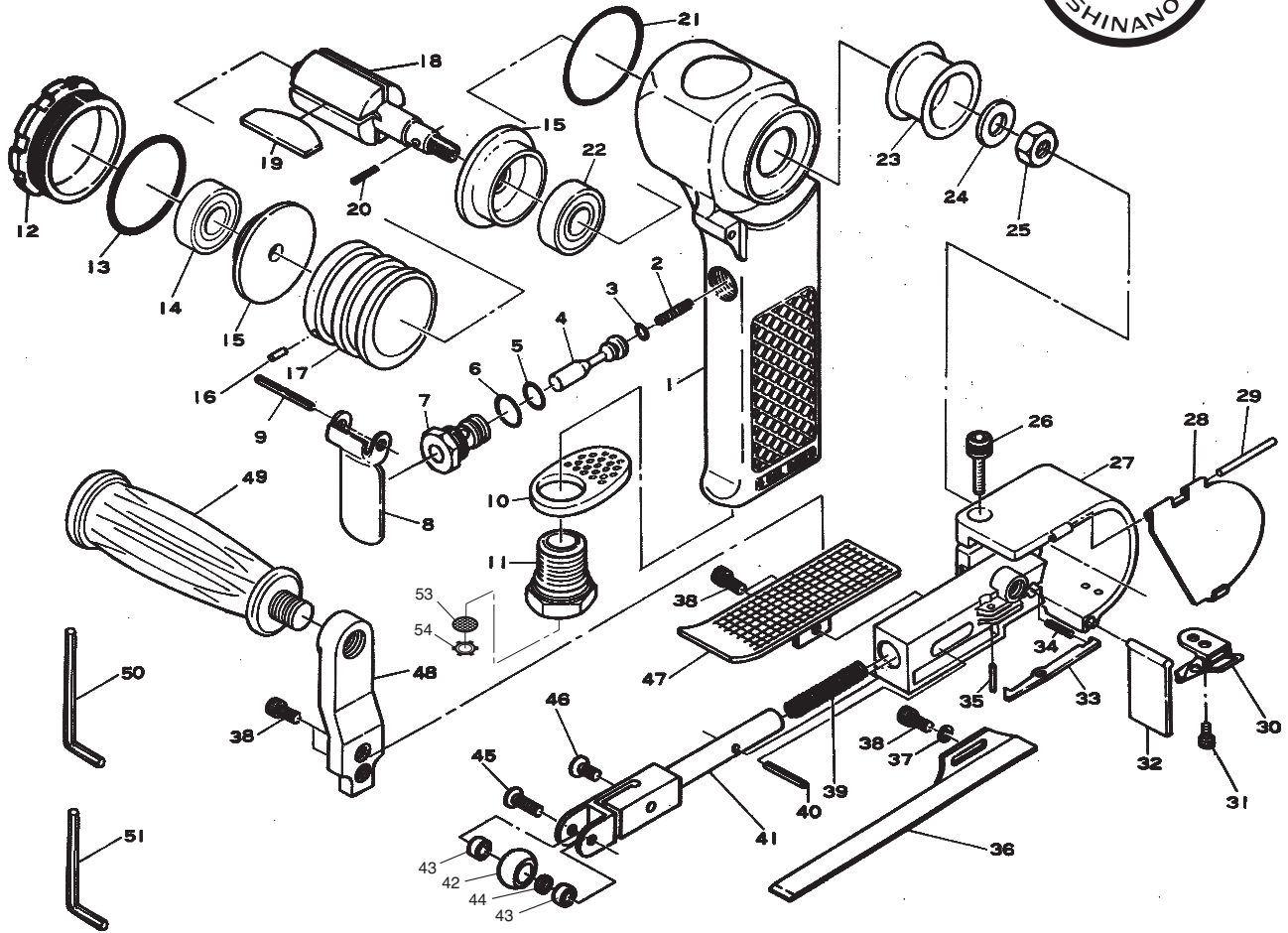

Ref. No.	Parts No.	Description	Q'ty	Ref. No.	Parts No.	Description	Q'ty
1	505-1	Motor Housing	1	28	507-42A	Wheel Cover Lid	1
2	482-46	Valve Spring	1	29	20-30	Roll Pin (2-30mm)	1
3	P-4	O-Ring	1	30	507-46	Cover Latch	1
4	485-1	Valve Stem	1	31	Z-M30-50	Cap Screw	2
5	P-8	O-Ring	1	32	505-32	Apron	1
6	S-10	O-Ring	1	33	507-41	Stopper	1
7	485-5	Valve Body	1	34	507-22	Stopper Spring	1
8	509-4	Throttle Lever	1	35	30-12	Roll Pin (3-12mm)	1
9	30-24	Roll Pin (3-24mm)	1	36	505-21	Shoe	1
10	509-3	Deflector	1	37	PW-50	Washer	1
11	509-2	Inlet Bushing	1	38	Z-1024-95	Cap Screw	5
12	505-5	Motor Nut	1	39	505-36	Tension Spring	1
13	J-2047	O-Ring	1	40	505-6	Stopper Pin	1
14	6001	Ball Bearing	1	41	505-33	Tension Arm	1
15	505-3	End Plate	2	42	505-38	Idle Pulley	1
16	25-5	Roll Pin (2.5-5mm)	1	43	606ZZ	Ball Bearing	2
17	505-4	Cylinder	1	44	505-40	Collar	1
18	505-2	Rotor	1	45	505-41	Idle Shaft	1
19	730-9	Rotor Blade	5	46	Y-M60-200	Cap Screw	1
20	310-19	Planet Pin	1	47	505-47	Finger Plate	1
21	S-50	O-Ring	1	48	505-50	Handle Bracket	1
22	6001ZZ	Ball Bearing	1	49	240B-2	Handle	1
23	505-26	Drive Pulley	1	50	WRA-5	5mm Allen Wrench	1
24	BT-80	Washer	1	51	WRA-4	4mm Allen Wrench	1
25	N2-M80	Nut	1	* 52	505-56Z/60	30mm Sanding Belt #60	6
26	Z-1024-180	Cap Screw	1	53	680-28A	Screen	1
27	505-29	Wheel Cover incl. Insert Spacer(505-37)	1	54	CRTW-12	Retainer	1