

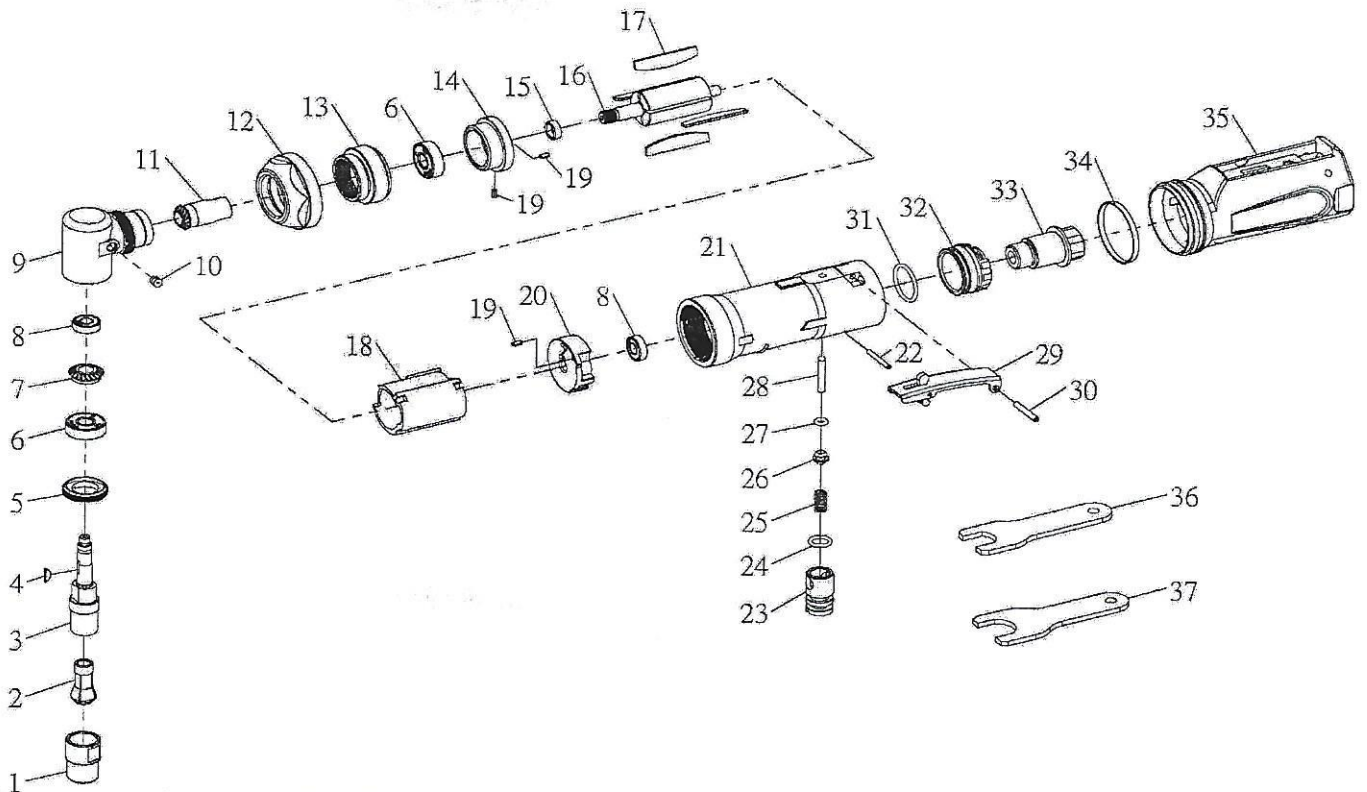

A-5527K 6MM Angle Die Grinder



Index No.	Parts No.	Description	Q'ty	Index No.	Parts No.	Description	Q'ty
1	5527K#01	Collet Nut	1	19	5527K#19	Spring Pin ($\psi 2.5 \times 5$)	3
2	5527K#02	1/4" Collet	1	20	5527K#20	Rear End Plate	1
3	5527K#03	Spindle	1	21	5527K#21	Motor Housing	1
4	5527K#04	Woodruff Key	1	22	5527K#22	Spring Pin ($\psi 2.5 \times 20$)	1
5	5527K#05	Clamp Nut	1	23	5527K#23	Valve Screw	1
6	5527K#06	Bearing (608ZZ)	2	24	5527K#24	O-Ring (P10A)	1
7	5527K#07	Spindle Gear	1	25	5527K#25	Valve Spring	1
8	5527K#08	Bearing (696ZZ)	2	26	5527K#26	Throttle Valve	1
9	5527K#09	Housing	1	27	5527K#27	O-Ring (P4)	1
10	5527K#10	Grease Fitting	1	28	5527K#28	Valve Shaft	1
11	5527K#11	Pinion	1	29	5527K#29	Safety Lever Ass'y	1
12	5527K#12	Coupling Nut	1	30	5527K#30	Spring Pin ($\psi 3 \times 22$)	1
13	5527K#13	Lock Ring	1	31	5527K#31	O-ring (S22.4)	1
14	5527K#14	Front End Plate	1	32	5527K#32	Exhaust Sleeve	1
15	5527K#15	Bearing Space	1	33	5527K#33	Inlet Bushing	1
16	5527K#16	Rotor	1	34	5527K#34	"O" Rubber Band	1
17	5527K#17	Rotor Blade	4	35	5527K#35	Housing Cover	1
18	5527K#18	Cylinder	1	36	5527K#36	(#17)Spanner Wrench Set	1
				37	5527K#37	(#11)Spanner Wrench Set	1

#17:Rotor Blade quote by SET.