

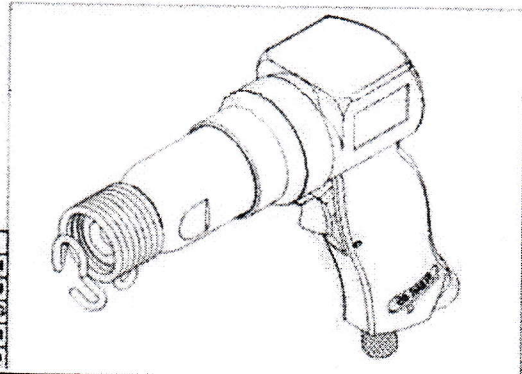

MŁOTEK ŚCINAK S-190KIT

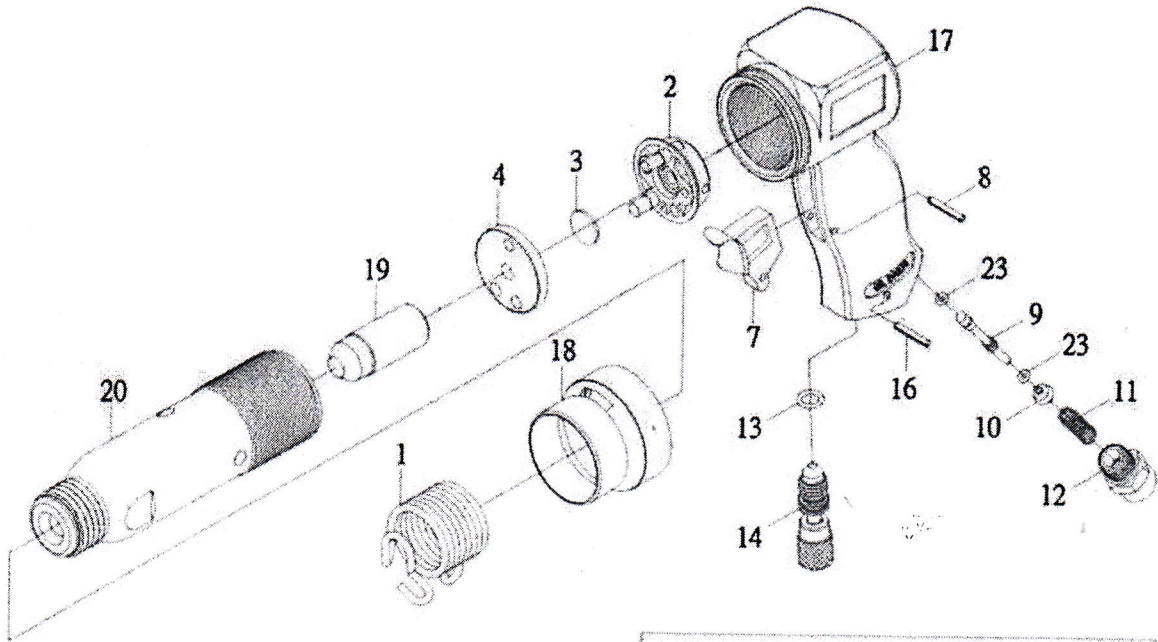

SPECIFICATION:			
*BLOW PER MINUTE (275)	3800 BPM	*BLOW PER MINUTE (273)	4500 BPM
*PISTON SIZE (275)(mm)	19*48	*PISTON SIZE (273)(mm)	19*28
*WEIGHT (275)	1.7 KG	*WEIGHT (273)	1.6 KG
*AIR CONS	18 CFM	*AIR PRESSURE	90 PSI
*AIR INLET	1/4"PT(NPT)	*HOSE SIZE	3/8"ID

INDE X NO.	PARTS NO	DESCRIPTION	Q'TY	INDE X NO.	PARTS NO	DESCRIPTION	Q'TY
1	19001	RETAINER SPRING	1	13	19013	O-RING (d7.8xw1.9)	1
2	19002	UPPER VALVE ASSY	1	14	19014	REGULATOR	1
3	19003	VALVE DISC	1	16	19016	SPRING PIN (∅3x18L)	1
4	19004	LOWER VALVE SEAT	1	17	19017	HANDLE	1
7	19007	TRIGGER	1	18	19018	EXHAUST SHIELD	1
8	19008	SPRING PIN (∅3x20L)	1	19	19019	PISTON-M	1
9	19009	VALVE STEM	1	20	19020A	CYLINDER-M-Round	1
10	19010	VALVE BALL	1		19020B	CYLINDER-M-Hex(10mm)	1
11	19011	THROTTLE SPRING	1		19020C	CYLINDER-M-Hex(11mm)	1
12	19012	AIR INLET BUSHING	1	23	19023	O-Ring (d2.5xw1.5)	2