

# SI-4710(F)

## Air Saw & File

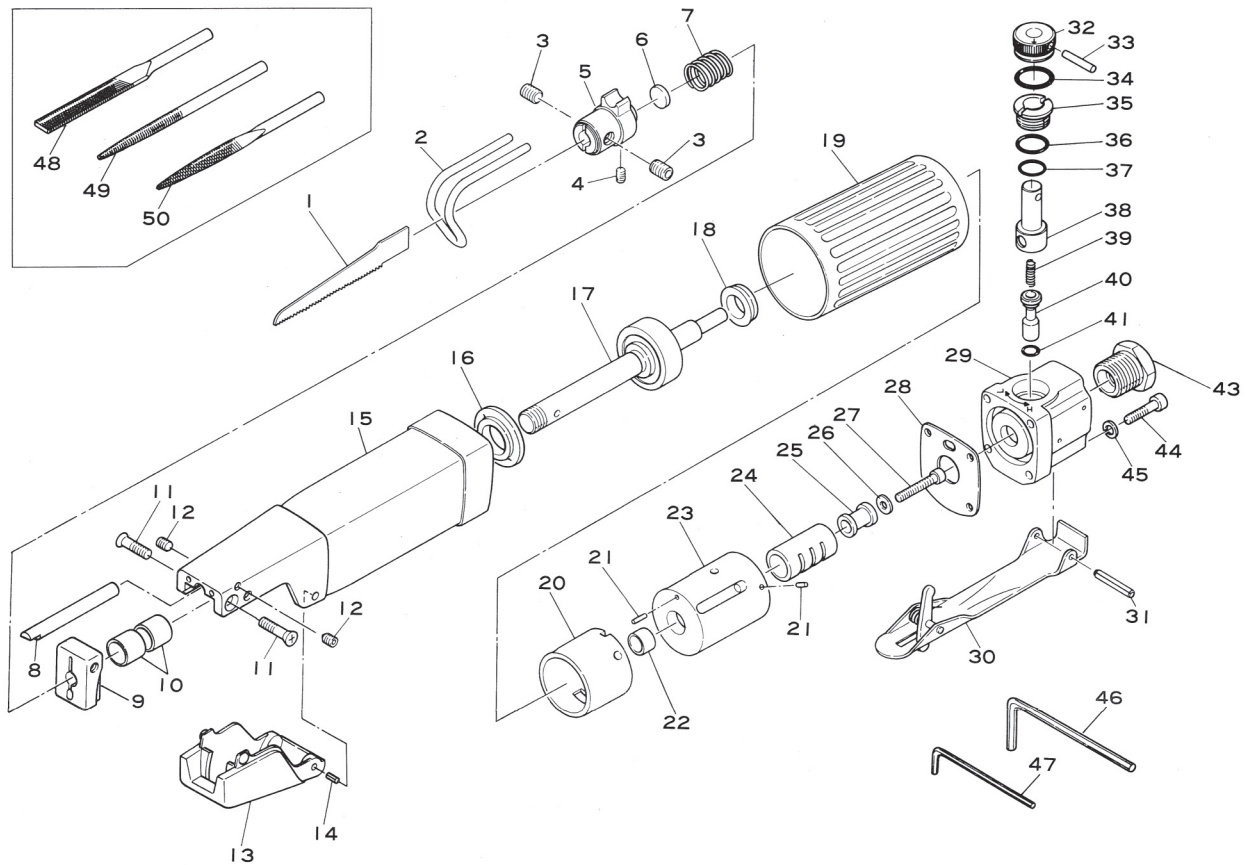

Ref. No.	Parts No.	Description	Q'ty	Ref. No.	Parts No.	Description	Q'ty
1	506-49AS1	Saw Blade 32T	1	28	506-22D	Gasket	1
2	506-2S	Work Guide Short	1	29	506B-23D	Valve Block incl. Valve Bush (330-4)	1
3	ROM80-60	Set Screw	2	30	506-48A	Throttle Lever	1
4	R3-M50-50	Set Screw	1	31	30-24	Roll Pin (3φ-24mm)	1
5	506PA-1D	Blade Chuck incl. Sleeve (506PA-1E)	1	32	506B-8	Regulator Dial	1
6	506P-3F	Spacer	1	33	30-15	Roll Pin (3φ-15mm)	1
7	506P-40	Spring	1	34	990-26-32	O-Ring	1
8	506P-11	Guide Pin	1	35	330-10	Valve Screw	1
9	506P-7	Blade Guide	1	36	P-10	O-Ring	1
10	506-11	Bush	2	37	P-8	O-Ring	1
11	Y-M40-100	Screw	2	38	506B-9	Air Regulator	1
12	ROM40-50	Set Screw	2	39	350-7	Valve Spring	1
13	506P-2	Chuck Cover	1	40	330-5	Valve Stem	1
14	30-6	Roll Pin (3φ-6mm)	2	41	P-4	O-Ring	1
15	506P-1	Housing	1	43	670-22SC	Inlet Bushing incl. Screen (680-28A) & Retainer (CRTW-12)	1
16	506-50D	Front Bumper	1	44	Z-832-190	Cap Screw	4
17	506P-10	Piston Rod Assy incl. Piston. Spacer & Nut (506-14B, 506-15A, 506-16)	1	45	HSW-40	Washer	4
18	506-51D	Rear Bumper	1	46	WRA-4	4mm Allen Wrench	1
19	506P-8	Housing Cover	1	47	WRA-2	2mm Allen Wrench	1
20	506-17	Cylinder	1	★48	506P-56F	Optional Square File	1
21	1500-68	Pin	2	★49	506P-56R	Optional Round File	1
22	506-12	Bush	1	★50	506P-56T	Optional Triangle File	1
23	506-19D	Valve Case	1	* 51	506-2L	Work Guide Long	1
24	506-18	Valve Sleeve	1				
25	506-20	Actuate Valve	1				
26	506-28	Washer	1				
27	Z-M30-220	Cap Screw	1				